

PRODUCT SPEC SHEET

P4K

24/7 production of small, ultra-high resolution end-use parts.

The P4K is the opposite of other, one-size-fits-all 3D printing solutions. With a range of models available, users can choose their optical configuration based on part size, feature-size requirements and throughput, and tailor a solution that best suits their needs. With resolutions of between 23 µm-90 µm on the X and Y axes, the P4K can easily produce detailed parts in a range of sizes.

Designed for a 24/7 production environment, the P4K can run lights-out, with little to no user intervention required. Easily print parts at volume with the quality, surface finish and tolerances needed for end-use applications.

MACHINE PROPERTIES*

Build Envelope (L x W x H)	P4K 35	90 x 56 x 180 mm (3.5 x 2.2 x 7.1 in)
	P4K 62	160 x 100 x 180 mm (6.3 x 3.9 x 7.1 in)
	P4K 75	192 x 120 x 180 mm (7.6 x 4.7 x 7.1 in)
	P4K 90	233 x 141.5 x 180 mm (9.1 x 5.7 x 7.1 in)
Native XY Resolution	P4K 35	35 µm
	P4K 62	62 µm
	P4K 75	75 µm
	P4K 90	90 µm
Z Resolution	25 - 150 µm	
Warranty	1 year back to factory included	
Footprint (L x W x H)	P4K 35, 62, 75	73 x 48 x 135 cm (28.7 x 18.9 x 53.1 in)
	P4K 90	73 x 48 x 160 cm (28.7 x 18.9 x 63.0 in)
Weight	P4K 35, 62, 75	87 kg (191.8 lb)
	P4K 90	89 kg (196.2 lb)
Electrical Requirements	100-120V, 5.4 Amp 220-240V, 2.4 Amp	

SYSTEM PROPERTIES

- Designed to run 24/7 in a production environment
- Material changeover can be done quickly and easily
- Delivered with all relevant software for automatic support generation and perfect part production

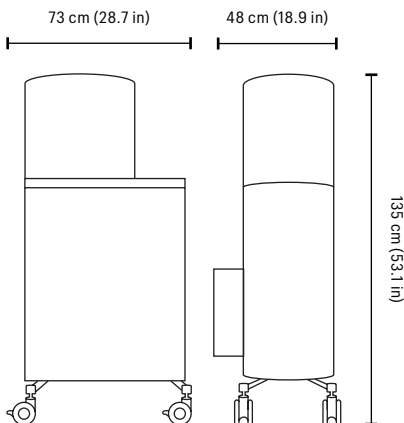

*Specifications are subject to change without notice.